

# ESP32-DevKitC V4 Getting Started Guide

This guide shows how to start using the ESP32-DevKitC V4 development board.

## What You Need

- [ESP32-DevKitC V4 board](#)
- USB A / micro USB B cable
- Computer running Windows, Linux, or macOS

You can skip the introduction sections and go directly to Section [Start Application Development](#).

## Overview

ESP32-DevKitC V4 is a small-sized ESP32-based development board produced by [Espressif](#). Most of the I/O pins are broken out to the pin headers on both sides for easy interfacing. Developers can either connect peripherals with jumper wires or mount ESP32-DevKitC V4 on a breadboard.

To cover a wide range of user requirements, the following versions of ESP32-DevKitC V4 are available:

- different ESP32 modules
  - [ESP32-WROOM-DA](#)
  - [ESP32-WROOM-32E](#)
  - [ESP32-WROOM-32UE](#)
  - [ESP32-WROOM-32D](#)
  - [ESP32-WROOM-32U](#)
  - [ESP32-SOLO-1](#)
  - [ESP32-WROVER-E](#)
  - [ESP32-WROVER-IE](#)
- male or female pin headers.

For details please refer to [ESP Product Selector](#).

## Functional Description

The following figure and the table below describe the key components, interfaces and controls of the ESP32-DevKitC V4 board.

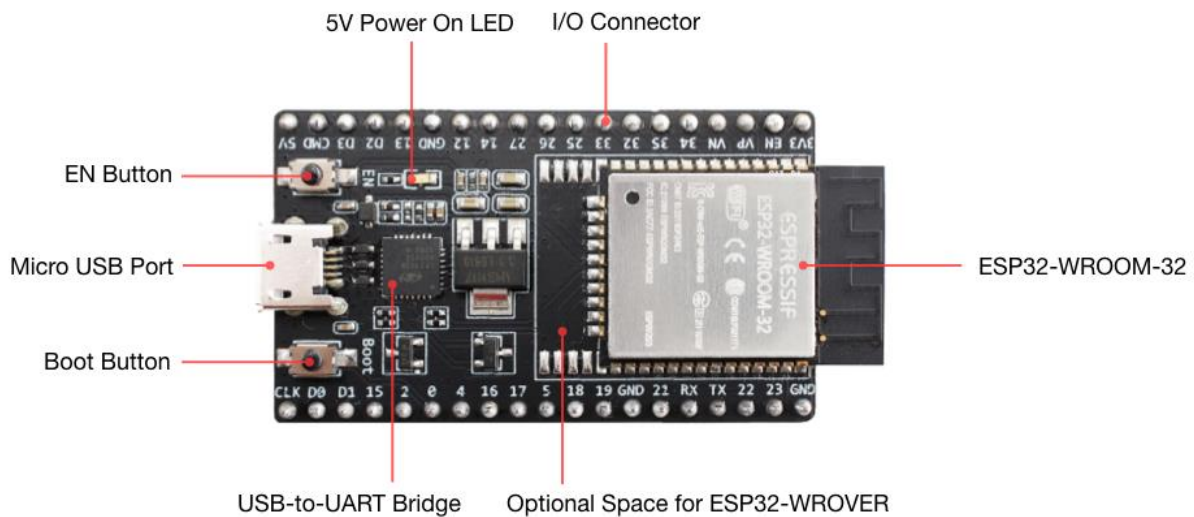

*ESP32-DevKitC V4 with ESP32-WROOM-32 module soldered*

### Key Component

### Description

ESP32-WROOM-32	A module with ESP32 at its core. For more information, see <a href="#">ESP32-WROOM-32 Datasheet</a> .
EN	Reset button.
Boot	Download button. Holding down <b>Boot</b> and then pressing <b>EN</b> initiates Firmware Download mode for downloading firmware through the serial port.
USB-to-UART Bridge	Single USB-UART bridge chip provides transfer rates of up to 3 Mbps.

## Key Component

## Description

Micro USB Port	USB interface. Power supply for the board as well as the communication interface between a computer and the ESP32-WROOM-32 module.
5V Power On LED	Turns on when the USB or an external 5V power supply is connected to the board. For details see the schematics in <a href="#">Related Documents</a> .
I/O	Most of the pins on the ESP module are broken out to the pin headers on the board. You can program ESP32 to enable multiple functions such as PWM, ADC, DAC, I2C, I2S, SPI, etc.

### Note

The pins D0, D1, D2, D3, CMD and CLK are used internally for communication between ESP32 and SPI flash memory. They are grouped on both sides near the USB connector. Avoid using these pins, as it may disrupt access to the SPI flash memory / SPI RAM.

### Note

The pins GPIO16 and GPIO17 are available for use only on the boards with the modules ESP32-WROOM and ESP32-SOLO-1. The boards with ESP32-WROVER modules have the pins reserved for internal use.

## Power Supply Options

There are three mutually exclusive ways to provide power to the board:

- Micro USB port, default power supply
- 5V / GND header pins
- 3V3 / GND header pins

### Warning

The power supply must be provided using **one and only one of the options above**, otherwise the board and/or the power supply source can be damaged.

## Header Block

The two tables below provide the **Name** and **Function** of I/O header pins on both sides of the board, as shown in [ESP32-DevKitC V4 with ESP32-WROOM-32 module soldered](#). The numbering and names are the same as in the [ESP32-DevKitC V4 schematics](#) (PDF).

## J1

No.	Name	Type	Function
1	3V3	P	3.3 V power supply
2	EN	I	CHIP_PU, Reset
3	IO36	I	GPIO36, ADC1_CH0, S_VP
4	IO39	I	GPIO39, ADC1_CH3, S_VN
5	IO34	I	GPIO34, ADC1_CH6, VDET_1
6	IO35	I	GPIO35, ADC1_CH7, VDET_2
7	IO32	I/O	GPIO32, ADC1_CH4, TOUCH_CH9, XTAL_32K_P
8	IO33	I/O	GPIO33, ADC1_CH5, TOUCH_CH8, XTAL_32K_N
9	IO25	I/O	GPIO25, ADC1_CH8, DAC_1
10	IO26	I/O	GPIO26, ADC2_CH9, DAC_2
11	IO27	I/O	GPIO27, ADC2_CH7, TOUCH_CH7
12	IO14	I/O	GPIO14, ADC2_CH6, TOUCH_CH6, MTMS
13	IO12	I/O	GPIO12, ADC2_CH5, TOUCH_CH5, MTDI
14	GND	G	Ground
15	IO13	I/O	GPIO13, ADC2_CH4, TOUCH_CH4, MTCK
16	IO9	I/O	GPIO9, D2
17	IO10	I/O	GPIO10, D3
18	IO11	I/O	GPIO11, CMD
19	5V0	P	5 V power supply

## J3

No.	Name	Type	Function
1	GND	G	Ground
2	IO23	I/O	GPIO23
3	IO22	I/O	GPIO22
4	IO1	I/O	GPIO1, U0TXD
5	IO3	I/O	GPIO3, U0RXD
6	IO21	I/O	GPIO21
7	GND	G	Ground
8	IO19	I/O	GPIO19
9	IO18	I/O	GPIO18
10	IO5	I/O	GPIO5
11	IO17	I/O	GPIO17
12	IO16	I/O	GPIO16
13	IO4	I/O	GPIO4, ADC2_CH0, TOUCH_CH0
14	IO0	I/O	GPIO0, ADC2_CH1, TOUCH_CH1, Boot
16	IO2	I/O	GPIO2, ADC2_CH2, TOUCH_CH2
17	IO15	I/O	GPIO15, ADC2_CH3, TOUCH_CH3, MTDO
17	IO8	I/O	GPIO8, D1
18	IO7	I/O	GPIO7, D0
19	IO6	I/O	GPIO6, SCK

P: Power supply; I: Input; O: Output.

## Pin Layout

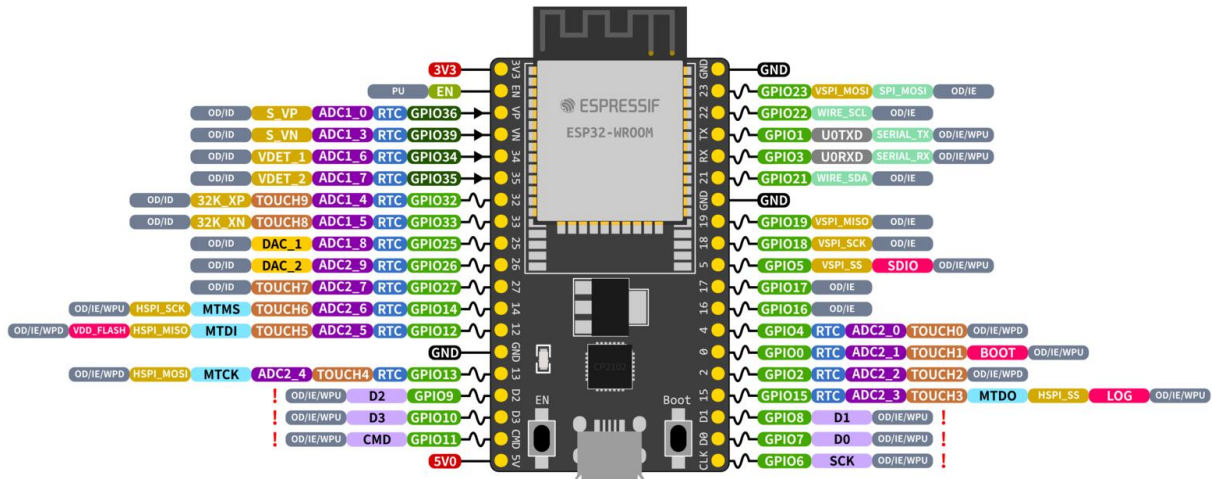

**ESP32 Specs**  
 32-bit Xtensa® dual-core @240MHz  
 Wi-Fi IEEE 802.11 b/g/n 2.4GHz  
 Bluetooth 4.2 BR/EDR and BLE  
 520 KB SRAM (16 KB for cache)  
 448 KB ROM  
 34 GPIOs, 4x SPI, 3x UART, 2x I2C,  
 2x I2S, RMT, LED PWM, 1 host SD/eMMC/SDIO,  
 1 slave SDIO/SPI, TWAI®, 12-bit ADC, Ethernet

PWM Capable Pin	GPIOX GPIO Input and Output	RTC RTC Power Domain (VDD3P3_RTC)	GPIO STATE
GPIOX GPIO Input Only	DAC_X Digital-to-Analog Converter	GND Ground	WPU: Weak Pull-up (Internal)
GPIOX GPIO Input and Output	DEBUG JTAG for Debugging	PWD Power Rails (3V3 and 5V)	WPD: Weak Pull-down (Internal)
FLASH External Flash Memory (SPI)	ADCX_CH Analog-to-Digital Converter	! Pin Shared with the Flash Memory	PU: Pull-up (External)
TOUCHX Touch Sensor Input Channel	OTHER Other Related Functions	! Can't be used as regular GPIO	IE: Input Enabled (After Reset)
SERIAL Serial for Debug/Programming	ARDUINO Arduino Related Functions		ID: Input Disabled (After Reset)
STRAP Strapping Pin Functions			OE: Output Enabled (After Reset)
			OD: Output Disabled (After Reset)

ESP32-DevKitC Pin Layout (click to enlarge)

## Note on C15

The component C15 may cause the following issues on earlier ESP32-DevKitC V4 boards:

- The board may boot into Download mode
- If you output clock on GPIO0, C15 may impact the signal

In case these issues occur, please remove the component. The figure below shows the location of C15 highlighted in yellow.

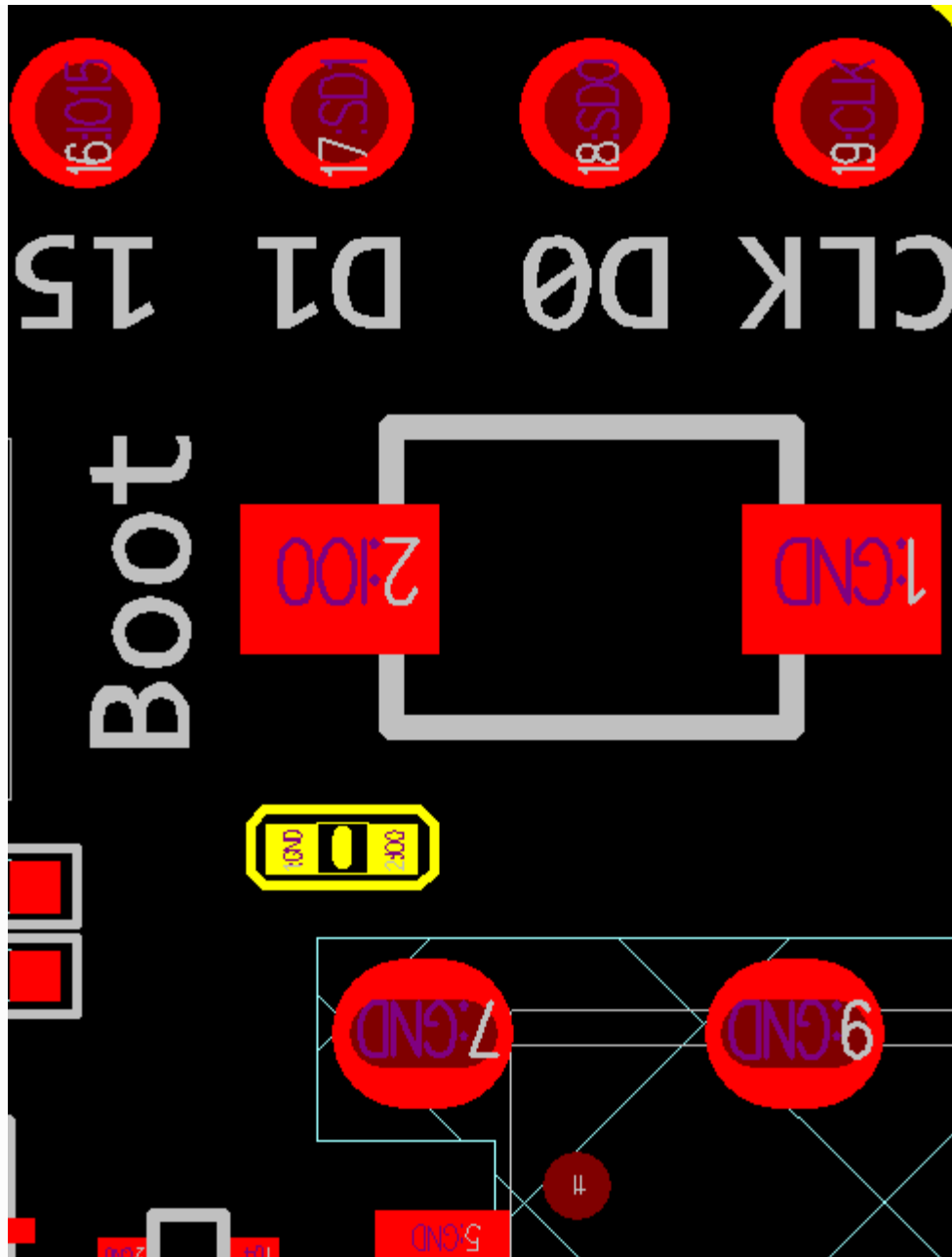

*Location of C15 (yellow) on ESP32-DevKitC V4 board*

## Start Application Development

Before powering up your ESP32-DevKitC V4, please make sure that the board is in good condition with no obvious signs of damage.

After that, proceed to [Get Started](#), where Section [Installation Step by Step](#) will quickly help you set up the development environment and then flash an example project onto your board.

## Board Dimensions

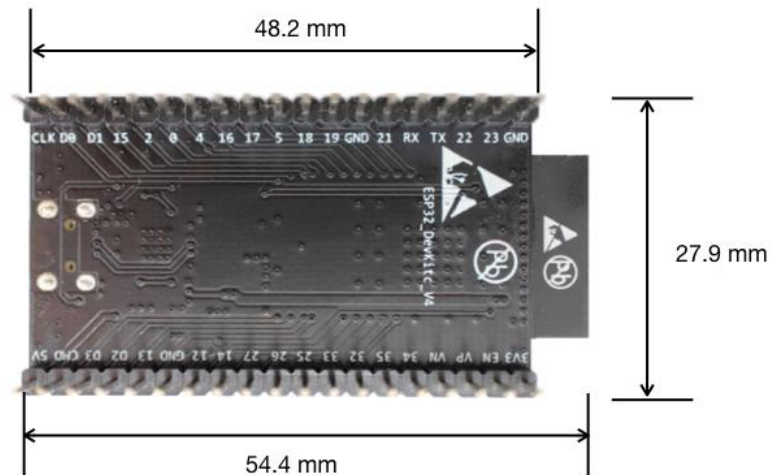

*Dimensions of ESP32-DevKitC board with ESP32-WROOM-32 module soldered - back (click to enlarge)*